

SY135C

Excavator



KEY FEATURES

- New design increases efficiency 12 percent while reducing fuel consumption 8 percent
- Four standard work modes for differing job-site conditions
- Redesigned chassis for excellent stability
- Standard features include two-way hydraulics, backfill blade and a pattern-control change valve to increase productivity

SPECIFICATIONS

Power

97.9 hp / 73.0 kW

Operating Weight

29,760 lb / 13 500 kg

Dig Depth

18' 1/2" / 5500 mm

Bucket Breakout

20,840 lbf / 92.7kN

318 Cooper Circle, Peachtree City, GA 30269

Tel: 678-251-2869 | Fax: 770-631-7731

Email: sales@sanyamerica.com

www.sanyamerica.com



SANY
AMERICA INC.

SY135C Dimensions & Specifications

Overall Dimensions

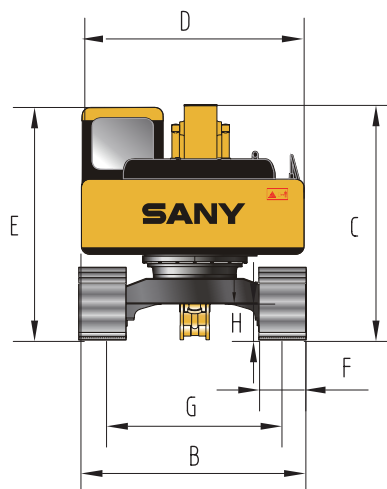
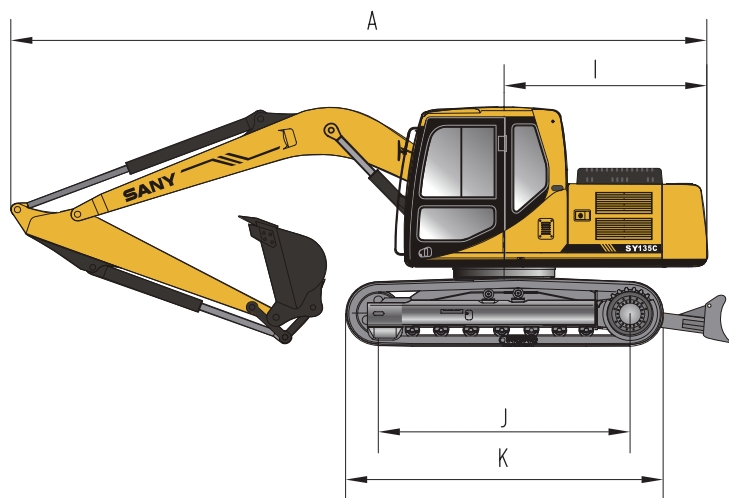

Overall Dimensions

	U.S. (ft - in)	Metric (mm)
A Transport Length	25' - 3.1"	7700
B Transport Width	8' - 4.4"	2550
C Transport Height	9' - 2.8"	2815
D Upper Width	8' - 2"	2490
E Blade Plate Height	8' - 11.9"	2740
F Std Track Shoe Width	1' - 7.7"	500
G Track Gauge	6' - 6.3"	1990
H Minimum Ground Clearance	1' - 4.7"	425
I Tail Swing Radius	7' - 2.8"	2205
J Length Center Idler to Center Sprocket	9' - 7.4"	2930
K Track Length	12' - 0.3"	3665
Boom Length	15' - 5"	4700
Std Arm Length	10' - 9.9"	3300

Machine Parameters

	U.S.	Metric
Weight	29,760 lb	13 500 kg
Rated Power	97.9 hp / 2000 rpm	73.0 kW / 2000 rpm
Engine Max Torque	278.8 lbf / 1600 rpm	378 Nm / 1600 rpm
Swing Speed	12 rpm	12 rpm
Travel Speed	3.4 / 2.2 mph	5.5 / 3.5 km/h
Draw Bar Pull (Tractive Effort)	22,931 lbf	102 kN
Max Arm Digging Force	14,867 lbf	66.13 kN
Max Bucket Digging Force	20,840 lbf	92.7 kN
Number of Upper Rollers	2	2
Number of Lower Rollers	7	7
Fuel Tank Capacity	63.4 gal	240 liters
Hydraulic Tank Capacity	39.6 gal	150 liters
Cooling System Capacity	5.8 gal	22 liters
Engine Oil Capacity	3.5 gal	13.2 liters
Ground Pressure (800 mm Shoes)	6.05 psi	41.7 kPa

Operating Range

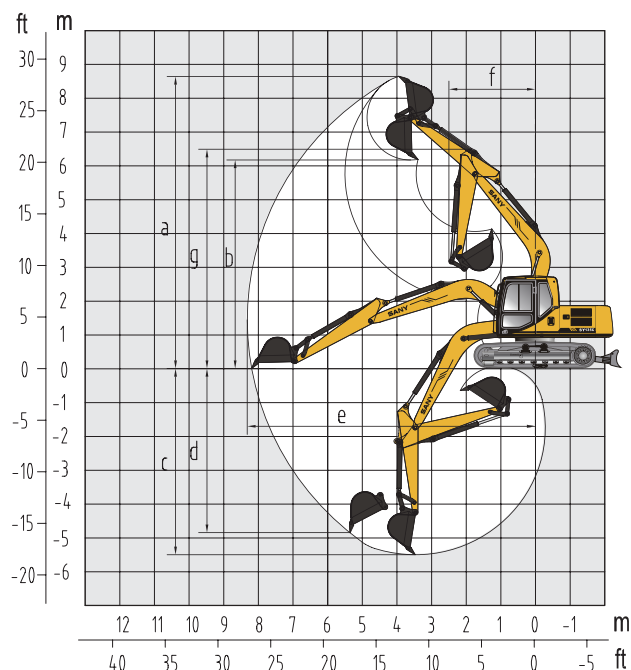

Operating Range

	U.S. (ft - in)	Metric (mm)
a Max Digging Height	28' - 4.4"	8645
b Max Dumping Height	20' - 3.1"	6175
c Max Digging Depth	18' - 0.5"	5500
d Max Vertical Wall Digging Depth	15' - 10.9"	4850
e Max Digging Reach	27' - 2.4"	8290
f Min Swing Radius	8' - 2.4"	2500
g Max Height at Minimum Swing Radius	21' - 3.9"	6500