

# KOMATSU

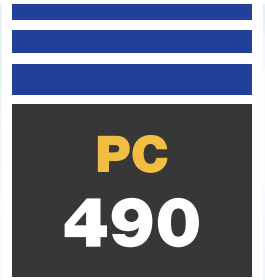

## Hydraulic Excavator **PC490/LC-10**

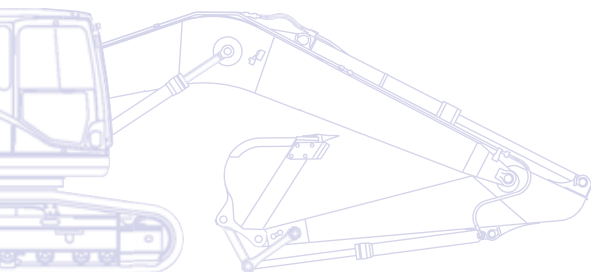

**ENGINE POWER**  
270 kW / 362 HP @ 1.900 rpm

**OPERATING WEIGHT**  
PC490-10: 46.630 - 47.570 kg  
PC490LC-10: 46.910 - 48.400 kg

**BUCKET CAPACITY**  
max. 3,50 m<sup>3</sup>

# Walk-Around

Built around the EU Stage IIIB/EPA Tier 4 interim engine platform, Komatsu's latest generation of excavators continues a long tradition of uncompromising quality and total customer support, while renewing a commitment to safety and environmental protection. Increased net horsepower, lower fuel consumption and emissions, and the advanced electronic control system that manages airflow rate, fuel injection and combustion parameters to optimize performance and further reduce particulate matter and nitrogen oxides in the exhaust: you can trust "Dash 10" machines to keep their promises of excellence.

## Powerful and environmentally friendly

- Low consumption EU Stage IIIB/EPA Tier 4 interim engine
- Fuel-saving engine and hydraulic technology
- Adjustable Eco-gauge and idle caution
- Reduced wastage

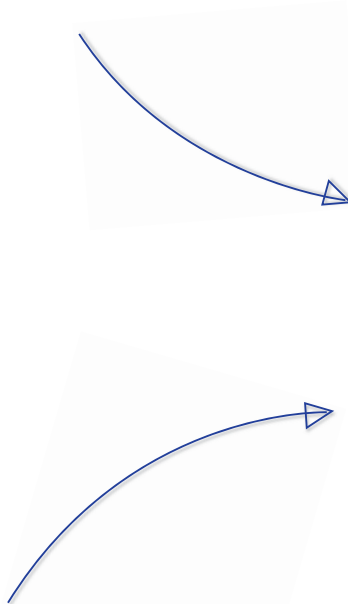

## Total versatility

- Ideal for a wide range of applications
- 6 working modes
- Two-mode boom control
- Wide choice of options
- Built-in versatility



# PC490-10

## ENGINE POWER

270 kW / 362 HP @ 1.900 rpm

## OPERATING WEIGHT

PC490-10: 46.630 - 47.570 kg  
PC490LC-10: 46.910 - 48.400 kg

## BUCKET CAPACITY

max. 3,50 m<sup>3</sup>

## First-class operator comfort

- Fully air suspended operator station
- Low noise design
- Low vibration levels
- Large, widescreen hi-res display monitor
- Improved operator convenience



## Highest safety standards

- Safe SpaceCab™  
ROPS compliant with ISO 12117-2:2008
- Low profile rear view camera
- Optimal jobsite safety
- Safe access, easy maintenance
- Falling Object Protection System (FOPS) optional



**KOMTRAX**

Komatsu Wireless  
Monitoring System

## Quality you can rely on

- Reliable and efficient
- Rugged design
- Komatsu-quality components
- Extensive dealer support network

# Total Versatility

## Ideal for a wide range of applications

Powerful and precise, the Komatsu PC490-10 is equipped to efficiently carry out any task your business requires. On big sites or small, for digging, trenching, landscaping or site preparation, the Komatsu original equipment hydraulic system always ensures maximum productivity and control.

## 6 working modes

Power, Lifting, Breaker, Economy, Attachment Power and Attachment Economy modes are all available, ensuring that the PC490-10 delivers the power you need with minimised fuel usage. The Economy mode can be adjusted for an ideal balance between power and economy to match your work. The oil flow delivered to hydraulic attachments is adjustable directly on the class-leading wide screen monitor panel.

## Built-in versatility

To further increase the PC490-10's versatility, one or two optional attachment lines can be added, the first one operated by a pedal or a sliding joystick push button, the other controlled only with a sliding joystick push button. Ten attachment memory settings are provided, with individually definable names. In combination with the standard-fit hydraulic quick coupler power circuit, changing working style is now even simpler.

## A wide choice of options

The PC490-10 is available with heavy duty features specifically designed to enhance lift capacity and productivity in tough loading applications. Heavy duty features available for PC490-10 include: short 6,7 m boom, double grouser track shoes, full length track roller guards and optional OPG top and front guard.

## Two-mode boom control

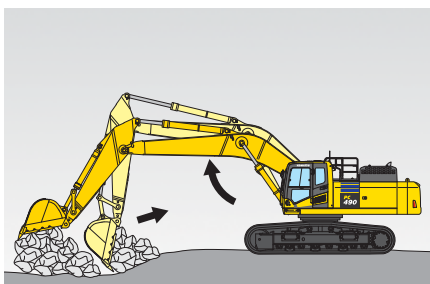

*Smooth mode*  
Boom floats upward, reducing lifting of machine front. This facilitates gathering blasted rock and scraping down operations.



*Power mode*  
Boom pushing force is increased, ditch digging and box digging operation on hard ground are improved.





# Powerful and Environmentally Friendly

## New Komatsu engine technology

The powerful and fuel-efficient Komatsu SAA6D125E-6-A engine in the PC490-10 delivers 270 kW/362 HP and is EU Stage IIIB/ EPA Tier 4 interim certified. To maximise power, fuel efficiency and emission compliance, it is turbo charged and features direct fuel injection, air-to-air after cooling and cooled EGR.

## Fuel-saving engine and hydraulic technology

The PC490-10 features variable speed matching of the engine and hydraulic pump, and an automatic low idle. The new engine and pump control technology lower total fuel consumption and guarantee efficiency and precision during single and combined movements.

## Adjustable Eco-gauge and idle caution

The new Eco-gauge can be set to target a fuel consumption value, encouraging the operator to work as efficiently as possible. And to further avoid wasting fuel when the machine is not actually working, a standard-fit idle caution is displayed if the engine idles for 5 minutes or more.

### **Komatsu Diesel Particulate Filter (KDPF)**

Komatsu's high efficiency DPf captures more than 90% of particulate matter. It includes a special oxidation catalyst with fuel injection system that can incinerate trapped particulates by either active or passive regeneration with no need to interrupt machine operations.

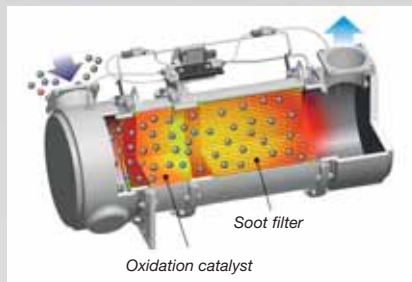

### **Exhaust Gas Recirculation (EGR)**

Cooled EGR is a technology well-proven in current Komatsu engines. The increased capacity of the EGR cooler now ensures very low NOx emissions and a better engine performance.

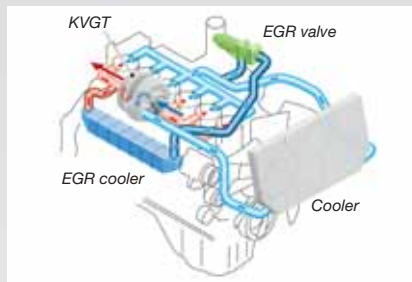

### **Komatsu Variable Geometry Turbo (KVGIT)**

The KVGIT provides optimal air flow to the engine combustion chamber under all speed and load conditions. Exhaust gas is cleaner, fuel economy is improved while machine power and performance are maintained.

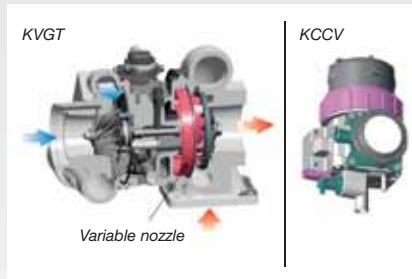

### **Komatsu Closed Crankcase Ventilation (KCCV)**

Crankcase emissions (blow-by gas) are passed through a CCV filter. The oil mist trapped in the filter is returned back to the crankcase while the filtered gas is returned to the air intake.

### **High-Pressure Common Rail (HPCR)**

To achieve complete fuel burn and lower exhaust emissions, the heavy duty High-Pressure Common Rail fuel injection system is computer controlled to deliver a precise quantity of pressurised fuel into the redesigned engine combustion chamber by multiple injections.

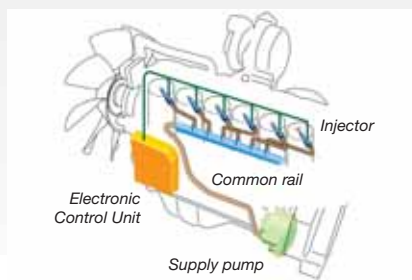



## Reduced wastage

Standard equipment on all PC490-10 includes an electric fuel pump, simple to operate and with an automatic shut-off. To further increase the system's safety, a barrier and special foams help to avoid any spilt fuel flowing towards hot areas of the machine.



# First-Class Operator Comfort

## Newly designed, spacious cab

The wide spacious cab features a new, fully air suspended operator control station that incorporates the side consoles mounted together with a high back, fully adjustable seat, heated for improved comfort.

## Improved operator convenience

With increased in-cab storage space, an auxiliary input (MP3 jack) and 12 V and 24 V power supply, the cab offers maximum convenience. The automatic air conditioner allows the operator to easily and precisely set the cab's atmosphere.

## Low noise design

Komatsu Dash 10 crawler excavators have very low external noise levels and are especially well-suited for work in confined spaces or urban areas. Reduced fan speed, a large capacity radiator, and the optimal usage of sound insulation and of sound absorbing materials help to make noise levels inside Dash 10 excavators comparable to those inside an executive car.

## Cab damper mounting

The built-in stability of the Komatsu PC490-10, combined with a highly rigid deck and a sprung multi-layer viscous mount system, drastically reduces vibration levels for the operator.



Automatic air conditioner



Hot and cool box



Joysticks with proportional control button for attachments





## Large, widescreen hi-res display monitor

To enable safe, accurate and smooth work, the user friendly monitor is the highly intuitive user interface for the machine's Equipment Management and Monitoring System (EMMS). Easily customized and with a choice of 25 languages, it features simple switches and multifunction keys that provide the operator with fingertip access to a wide range of functions and operating information.



# Highest Safety Standards

## Safe SpaceCab™

The new cab is ROPS compliant with ISO 12117-2:2008. It has a tubular steel frame and provides very high shock absorbency, impact resistance and durability. The seat belt is designed to keep the operator in the safety zone of the cab in the event of a roll-over. Optionally it can be fitted with an ISO 10262 Level 2 Falling Object Protective System (FOPS) with openable front guard.

## Safe and easy maintenance

Thermal guards are placed around high temperature parts of the engine. The fan belt and pulleys are well protected and in case of damage, fire risk is reduced by a pump/engine partition that prevents hydraulic oil from spraying onto the engine. The engine hood is hinged to the rear, with anti-slip plates positioned around the engine bay to ensure safe and easy access from all sides. Exceptionally sturdy handrails further contribute to a high safety level.

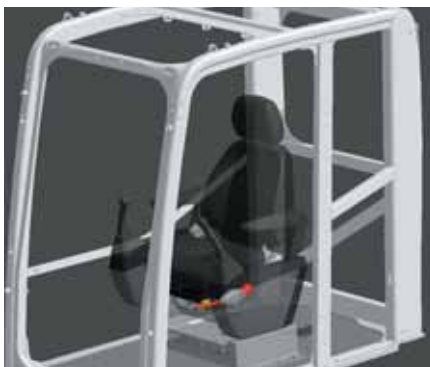

Safe SpaceCab™

## Optimal job site safety

Safety features on the Komatsu PC490-10 comply with the latest industry standards and work together as a system to minimise risks to personnel in and around the machine. An audible travel alarm further promotes job site safety. Highly durable anti-slip plates – with additional high friction covering – maintain long term traction performance.

## Rear view camera

A standard fitment camera gives an exceptionally clear view of the rear work zone on the wide-screen monitor panel. The low profile camera is adjustable and integrated into the counterweight's shape. On request, another camera can be added to the right side of the machine.



Low profile rear view camera



Large handrails





# Quality You Can Rely On

## Reliable and efficient

Productivity is the key to success – all major components of the PC490-10 are designed and directly manufactured by Komatsu. Essential machine functions are perfectly matched for a highly reliable and productive machine.

## Rugged design

Maximum toughness and durability – along with top class customer service – are the cornerstones of Komatsu's philosophy. Single piece plates and castings are used in key areas of the machine's structure for good load distribution. Highly durable rubbing strips on the underside of the arm protect the structure against impact damage. Plate dimensions on the new unique undercarriage were increased to deliver exceptional stability, improved lifting capacity, and more durability.

## Komatsu-quality components

With the latest computer design techniques and a thorough test programme, Komatsu's global know-how produces machines that are designed, manufactured and tested to meet your highest standards.

## Extensive dealer support network

The extensive Komatsu distribution and dealer network is standing by to help keep your fleet in optimum condition. Customised servicing packages are available, with express availability of spare parts, to make sure that your Komatsu will continue to perform at its peak.



Cast boom foot



Single piece boom plates



# Komatsu Wireless Monitoring System

## The easy way to higher productivity

KOMTRAX™ is the latest in wireless monitoring technology. It delivers insightful and cost saving information about your fleet and equipment and offers you a wealth of information to facilitate peak machine performance. By creating a tightly integrated web of support it allows pro active and preventive maintenance and helps you to efficiently run a business.

## Knowledge

You get quick answers to basic and critical questions about your machines - what they're doing, when they did it, where they're located, how they can be used more efficiently, and when they need to be serviced. Performance data is relayed by satellite from your machine to your computer and to your local Komatsu distributor - who's readily available for expert analysis and feedback.

## Convenience

KOMTRAX™ helps to conveniently manage your fleet on the web, wherever you are. Data is analysed and packaged specifically for easy and intuitive viewing in maps, lists, graphs and charts. You can anticipate the type of service and parts your machines could require, or troubleshoot problems before Komatsu technicians arrive on site.





## Power

The detailed information that KOMTRAX™ puts at your fingertips 24 hours a day, 7 days a week gives you the power to make better daily and long-term strategic decisions. You can anticipate problems, customize maintenance schedules, minimize downtime and keep your machines where they belong – working on the job site.



Through the web application, a variety of search parameters are available to quickly find information about specific machines based on key factors such as utilization rates, age, various notification messages, and more.

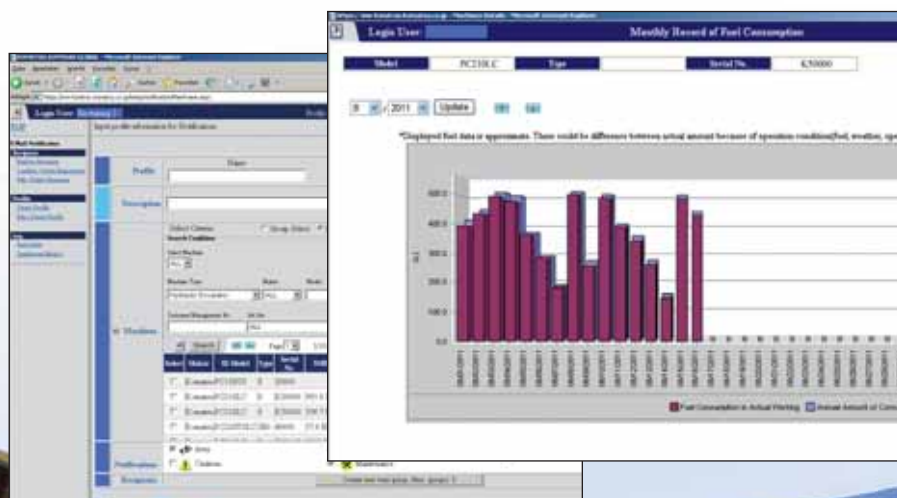

A simple chart shows the machine's fuel consumption and helps you to calculate total costs for a job site and conveniently schedule fuel deliveries.

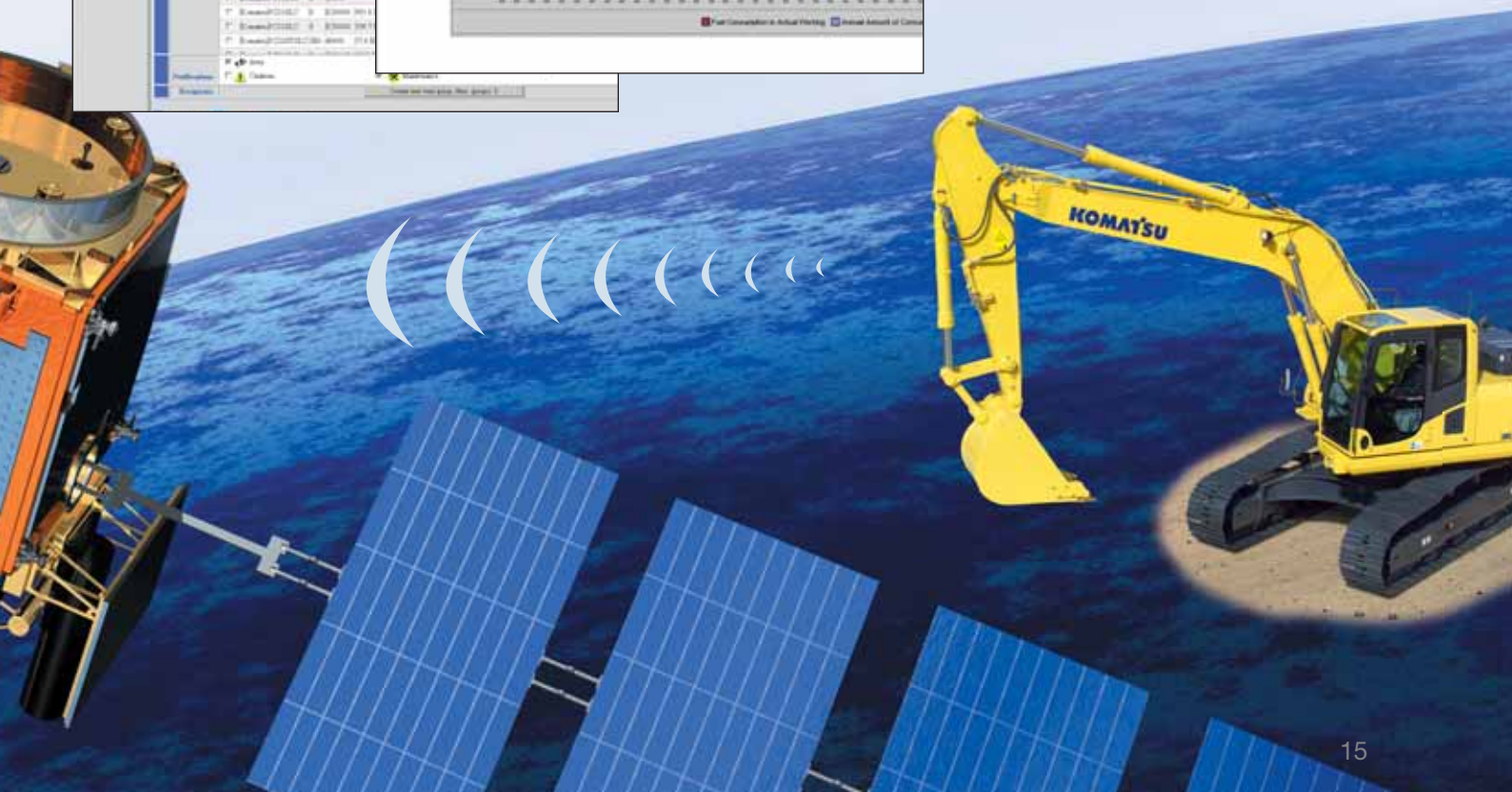

# Easy Maintenance

## Easy cleaning of coolers

Hinged air conditioning cooler and side-by-side radiator and oil cooler allow easy access for cleaning.



## Quick access to filters and fuel drain valve

The engine oil filter, the fuel filters and the fuel drain valve are mounted conveniently to make them easily accessible.



## Diesel particulate filter regeneration

Soot trapped in the diesel particulate filter is periodically and automatically oxidized using the heat from the engine exhaust.



## Water separator

This is standard equipment which removes any water that has become mixed with the fuel, preventing fuel system damage.



## Washable floor

The floor is easy to keep clean. The gently inclined surface has a flanged floormat and drainage holes to facilitate runoff.

## Inclined track frame

The track frame is sloped so that dirt will not accumulate and can be removed easily.

## Long-life oil filters

The hydraulic oil filter uses high-performance filtering material for long element replacement intervals, which significantly reduces maintenance costs.



## Flexible warranty

When you purchase Komatsu equipment, you gain access to a broad range of programmes and services that have been designed to help you get the most from your investment. For example, Komatsu's Flexible Warranty Programme provides a range of extended warranty options on the machine and its components. These can be chosen to meet your individual needs and activities. This programme is designed to help reduce total operating costs.





## ENGINE

Model .....	Komatsu SAA6D125E-6-A
Type .....	Common rail direct injection, water-cooled, emissionised, turbocharged, after-cooled diesel
Engine power	
at rated engine speed .....	1.900 rpm
ISO 14396 .....	270 kW/362 HP
ISO 9249 (net engine power) .....	268 kW/359 HP
No. of cylinders .....	6
Bore x stroke .....	125 x 150 mm
Displacement .....	11,04 ltr
Battery .....	2 x 12 V/110 Ah
Alternator .....	24 V/60 A
Starter motor .....	24 V/11 kW
Air filter type .....	Double element type with monitor panel dust indicator and auto dust evacuator
Cooling .....	Suction type cooling fan with radiator fly screen
Fan drive type .....	Hydraulic, reversible

## HYDRAULIC SYSTEM

Type .....	HydrauMind. Closed-centre system with load sensing and pressure compensation valves
Additional circuits .....	2 additional circuits with proportional control can be installed
Main pump .....	2 variable displacement piston pumps supplying boom, arm, bucket, swing and travel circuits
Maximum pump flow .....	2 x 345 ltr/min
Relief valve settings	
Implement .....	380 kg/cm <sup>2</sup>
Travel .....	380 kg/cm <sup>2</sup>
Swing .....	285 kg/cm <sup>2</sup>
Pilot circuit .....	33 kg/cm <sup>2</sup>

## UNDERCARRIAGE

Construction .....	X-frame centre section with box section track frames
Track assembly	
Type .....	Fully sealed
Shoes (each side) .....	46 (PC490), 49 (PC490LC)
Tension .....	Combined spring and hydraulic unit
Rollers	
Track rollers (each side) .....	7 (PC490), 8 (PC490LC)
Carrier rollers (each side) .....	2

## OPERATING WEIGHT (APPR.)

	PC490-10		PC490LC-10	
	Operating weight	Ground pressure	Operating weight	Ground pressure
Triple grouser shoes				
600 mm	46.630 kg	0,89 kg/cm <sup>2</sup>	46.910 kg	0,83 kg/cm <sup>2</sup>
700 mm	47.100 kg	0,77 kg/cm <sup>2</sup>	47.410 kg	0,72 kg/cm <sup>2</sup>
800 mm	47.570 kg	0,68 kg/cm <sup>2</sup>	47.910 kg	0,64 kg/cm <sup>2</sup>
900 mm	-	-	48.400 kg	0,57 kg/cm <sup>2</sup>
Double grouser shoes				
600 mm	46.750 kg	0,89 kg/cm <sup>2</sup>	47.030 kg	0,83 kg/cm <sup>2</sup>

Operating weight, including specified work equipment, 7,1 m mono boom, 3,4 m arm, 1.915 kg bucket, operator, lubricant, coolant, full fuel tank and the standard equipment.

## SWING SYSTEM

Type .....	Axial piston motor driving through planetary double reduction gearbox
Swing lock .....	Electrically actuated wet multi-disc brake integrated into swing motor
Swing speed .....	0 - 9,4 rpm
Swing torque .....	132 kNm

## DRIVES AND BRAKES

Steering control .....	2 levers with pedals giving full independent control of each track
Drive method .....	Hydrostatic
Travel operation .....	Automatic 3-speed selection
Gradeability .....	70%, 35°
Max. travel speeds	
Lo / Mi / Hi .....	3,0 / 4,2 / 5,5 km/h
Maximum drawbar pull .....	34.000 kg
Brake system .....	Hydraulically operated discs in each travel motor

## SERVICE REFILL CAPACITIES

Fuel tank .....	650 ltr
Radiator .....	44,0 ltr
Engine oil .....	37,0 ltr
Swing drive .....	20,0 ltr
Hydraulic tank .....	248 ltr
Final drive (each side) .....	10,5 ltr

## ENVIRONMENT

Engine emissions .....	Fully complies with EU Stage IIIB and EPA Tier 4 interim exhaust emission regulations
Noise levels	
LwA external .....	107 dB(A) (2000/14/EC Stage II)
LpA operator ear .....	71 dB(A) (ISO 6396 dynamic test)
Vibration levels (EN 12096:1997)*	
Hand/arm .....	≤ 2,5 m/s <sup>2</sup> (uncertainty K = 0,25 m/s <sup>2</sup> )
Body .....	≤ 0,5 m/s <sup>2</sup> (uncertainty K = 0,10 m/s <sup>2</sup> )

\* for the purpose of risk assessment under directive 2002/44/EC, please refer to ISO/TR 25398:2006.

# Dimensions & Performance Figures

MACHINE DIMENSIONS	PC490-10	PC490LC-10
A Overall width of upper structure	2.995 mm	2.995 mm
B Overall height of cab	3.360 mm	3.360 mm
C Overall length of basic machine	6.130 mm	6.300 mm
D Tail length	3.605 mm	3.605 mm
Tail swing radius	3.645 mm	3.645 mm
E Clearance under counterweight	1.385 mm	1.385 mm
F Machine tail height	2.490 mm	2.490 mm
F' Machine tail height (top of engine cover)	3.105 mm	3.105 mm
G Ground clearance	700 mm	700 mm
H Tumbler centre distance	4.020 mm	4.350 mm
I Track length	5.055 mm	5.385 mm
J Track gauge	2.890 mm	2.890 mm
K Track shoe width	600, 700, 800 mm	600, 700, 800, 900 mm
L Overall track width with 600 mm shoes	3.490 - *2.990 mm	3.490 - *2.990 mm
Overall track width with 700 mm shoes	3.590 - *3.090 mm	3.590 - *3.090 mm
Overall track width with 800 mm shoes	3.690 - *3.190 mm	3.690 - *3.190 mm
Overall track width with 900 mm shoes	-	3.790 - *3.290 mm

\* Transport dimensions (retracted)

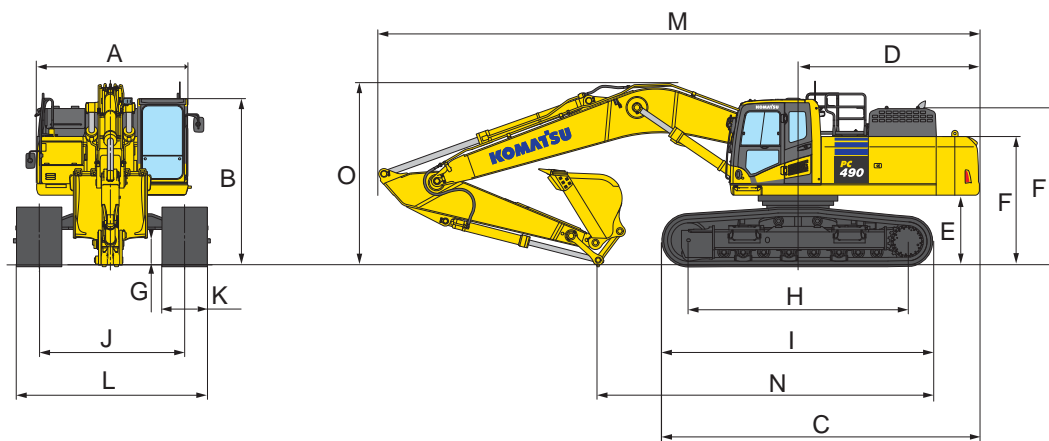

## TRANSPORT DIMENSIONS

## MONO BOOM

Arm length	2,4 m	2,9 m	3,4 m	4,0 m	4,8 m
M Transport length	11.910 mm	12.000 mm	11.930 mm	11.950 mm	11.825 mm
N Length on ground (transport) (PC490-10)	7.720 mm	7.455 mm	6.710 mm	6.130 mm	5.885 mm
Length on ground (transport) (PC490LC-10)	7.885 mm	7.620 mm	6.875 mm	6.295 mm	6.050 mm
O Overall height (to top of boom)	3.875 mm	3.760 mm	3.635 mm	3.885 mm	4.435 mm

## TRANSPORT DIMENSIONS

## SHORT BOOM

Arm length	2,4 m	2,9 m
M Transport length	11.470 mm	11.570 mm
N Length on ground (transport) (PC490-10)	7.675 mm	7.210 mm
Length on ground (transport) (PC490LC-10)	7.840 mm	7.380 mm
O Overall height (to top of boom)	3.630 mm	3.710 mm

**PC490-10 / MAX. BUCKET CAPACITY AND WEIGHT**

MONO BOOM						
Arm length	2,4 m	2,9 m	3,4 m	4,0 m	4,8 m	
Material weight up to 1,2 t/m <sup>3</sup>	2,76 m <sup>3</sup> 2.175 kg	2,76 m <sup>3</sup> 2.175 kg	2,76 m <sup>3</sup> 2.175 kg	2,76 m <sup>3</sup> 2.175 kg	2,76 m <sup>3</sup> 2.175 kg	2,76 m <sup>3</sup> 2.175 kg
Material weight up to 1,5 t/m <sup>3</sup>	2,76 m <sup>3</sup> 2.175 kg	2,76 m <sup>3</sup> 2.175 kg	2,76 m <sup>3</sup> 2.175 kg	2,76 m <sup>3</sup> 2.175 kg	2,76 m <sup>3</sup> 2.175 kg	2,74 m <sup>3</sup> 2.175 kg
Material weight up to 1,8 t/m <sup>3</sup>	2,76 m <sup>3</sup> 2.175 kg	2,76 m <sup>3</sup> 2.175 kg	2,71 m <sup>3</sup> 2.175 kg	2,71 m <sup>3</sup> 2.175 kg	2,71 m <sup>3</sup> 2.175 kg	2,39 m <sup>3</sup> 2.015 kg

**PC490-10 / MAX. BUCKET CAPACITY AND WEIGHT**

SHORT BOOM			
Arm length	2,4 m	2,9 m	
Material weight up to 1,2 t/m <sup>3</sup>	3,50 m <sup>3</sup> 2.450 kg	3,50 m <sup>3</sup> 2.450 kg	
Material weight up to 1,5 t/m <sup>3</sup>	3,50 m <sup>3</sup> 2.450 kg	3,50 m <sup>3</sup> 2.450 kg	
Material weight up to 1,8 t/m <sup>3</sup>	3,18 m <sup>3</sup> 2.432 kg	2,95 m <sup>3</sup> 2.308 kg	

**PC490LC-10 / MAX. BUCKET CAPACITY AND WEIGHT**

MONO BOOM						
Arm length	2,4 m	2,9 m	3,4 m	4,0 m	4,8 m	
Material weight up to 1,2 t/m <sup>3</sup>	2,76 m <sup>3</sup> 2.175 kg	2,76 m <sup>3</sup> 2.175 kg	2,76 m <sup>3</sup> 2.175 kg	2,76 m <sup>3</sup> 2.175 kg	2,76 m <sup>3</sup> 2.175 kg	2,76 m <sup>3</sup> 2.175 kg
Material weight up to 1,5 t/m <sup>3</sup>	2,76 m <sup>3</sup> 2.175 kg	2,76 m <sup>3</sup> 2.175 kg	2,76 m <sup>3</sup> 2.175 kg	2,76 m <sup>3</sup> 2.175 kg	2,76 m <sup>3</sup> 2.175 kg	2,76 m <sup>3</sup> 2.175 kg
Material weight up to 1,8 t/m <sup>3</sup>	2,76 m <sup>3</sup> 2.175 kg	2,76 m <sup>3</sup> 2.175 kg	2,76 m <sup>3</sup> 2.175 kg	2,75 m <sup>3</sup> 2.175 kg	2,75 m <sup>3</sup> 2.175 kg	2,45 m <sup>3</sup> 2.048 kg

**PC490LC-10 / MAX. BUCKET CAPACITY AND WEIGHT**

SHORT BOOM			
Arm length	2,4 m	2,9 m	
Material weight up to 1,2 t/m <sup>3</sup>	3,50 m <sup>3</sup> 2.450 kg	3,50 m <sup>3</sup> 2.450 kg	
Material weight up to 1,5 t/m <sup>3</sup>	3,50 m <sup>3</sup> 2.450 kg	3,50 m <sup>3</sup> 2.450 kg	
Material weight up to 1,8 t/m <sup>3</sup>	3,50 m <sup>3</sup> 2.450 kg	3,50 m <sup>3</sup> 2.450 kg	

Max. capacity and weight have been calculated according to ISO 10567:2007.

Please consult with your distributor for the correct selection of buckets and attachments to suit the application.

**BUCKET AND ARM FORCE**

Arm length	2,4 m	2,9 m	3,4 m	4,0 m	4,8 m
Bucket digging force	26.100 kg	26.100 kg	26.100 kg	26.100 kg	26.100 kg
Bucket digging force at PowerMax	28.000 kg	28.000 kg	28.000 kg	28.000 kg	28.000 kg
Arm crowd force	24.200 kg	24.400 kg	20.400 kg	18.100 kg	15.800 kg
Arm crowd force at PowerMax	25.900 kg	26.200 kg	21.800 kg	19.400 kg	17.000 kg

# Working Range

## MONO BOOM

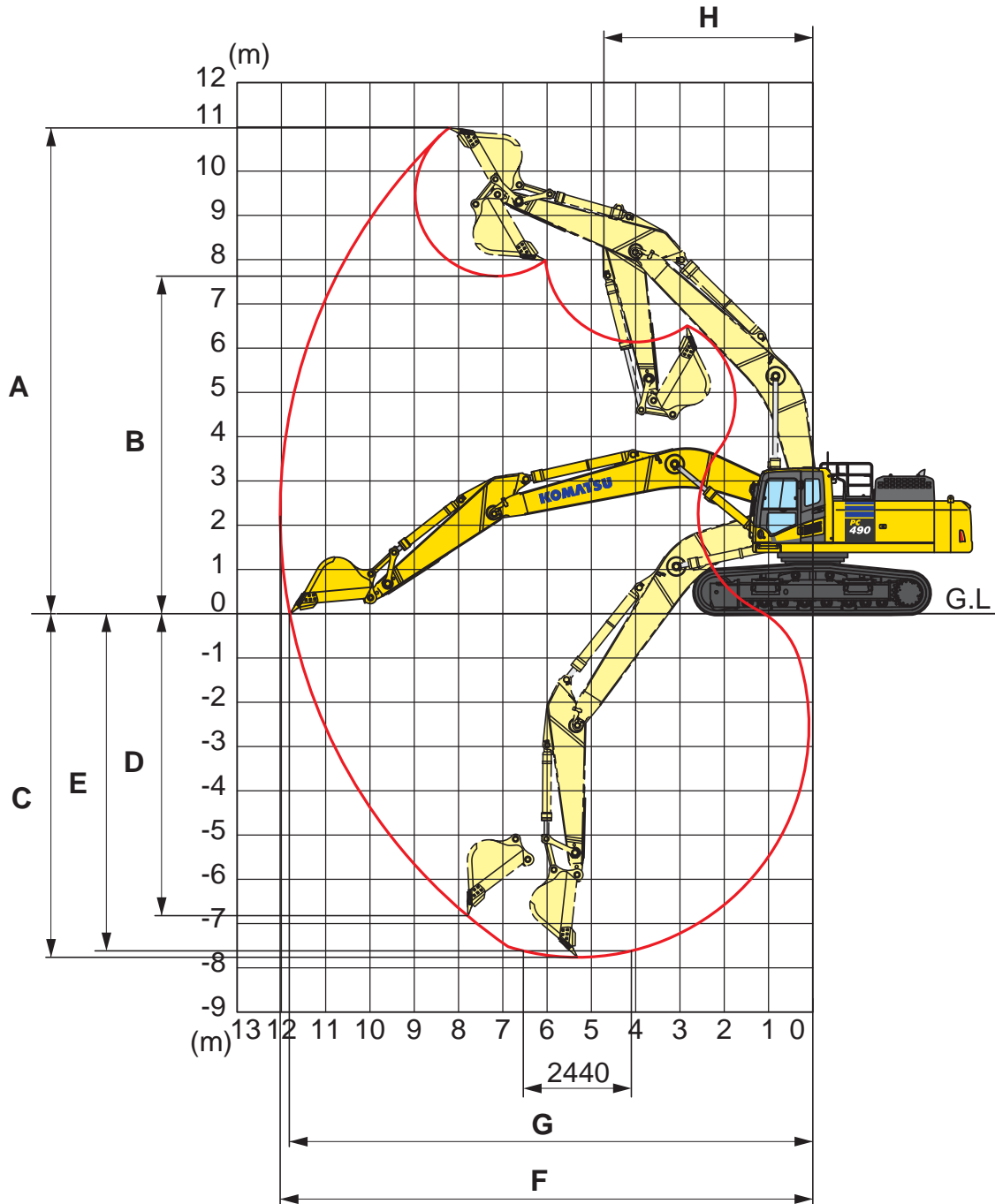

ARM LENGTH	2,4 m	2,9 m	3,4 m	4,0 m	4,8 m
A Max. digging height	10.375 mm	10.350 mm	10.980 mm	11.090 mm	11.550 mm
B Max. dumping height	7.135 mm	7.145 mm	7.630 mm	7.780 mm	8.210 mm
C Max. digging depth	6.780 mm	7.280 mm	7.755 mm	8.380 mm	9.190 mm
D Max. vertical wall digging depth	5.240 mm	5.635 mm	6.805 mm	7.220 mm	8.085 mm
E Max. digging depth of cut for 2,44 m level	6.585 mm	7.090 mm	7.615 mm	8.250 mm	9.080 mm
F Max. digging reach	11.080 mm	11.445 mm	12.030 mm	12.565 mm	13.365 mm
G Max. digging reach at ground level	10.840 mm	11.215 mm	11.810 mm	12.355 mm	13.170 mm
H Min. swing radius	4.835 mm	4.810 mm	4.735 mm	4.800 mm	4.885 mm



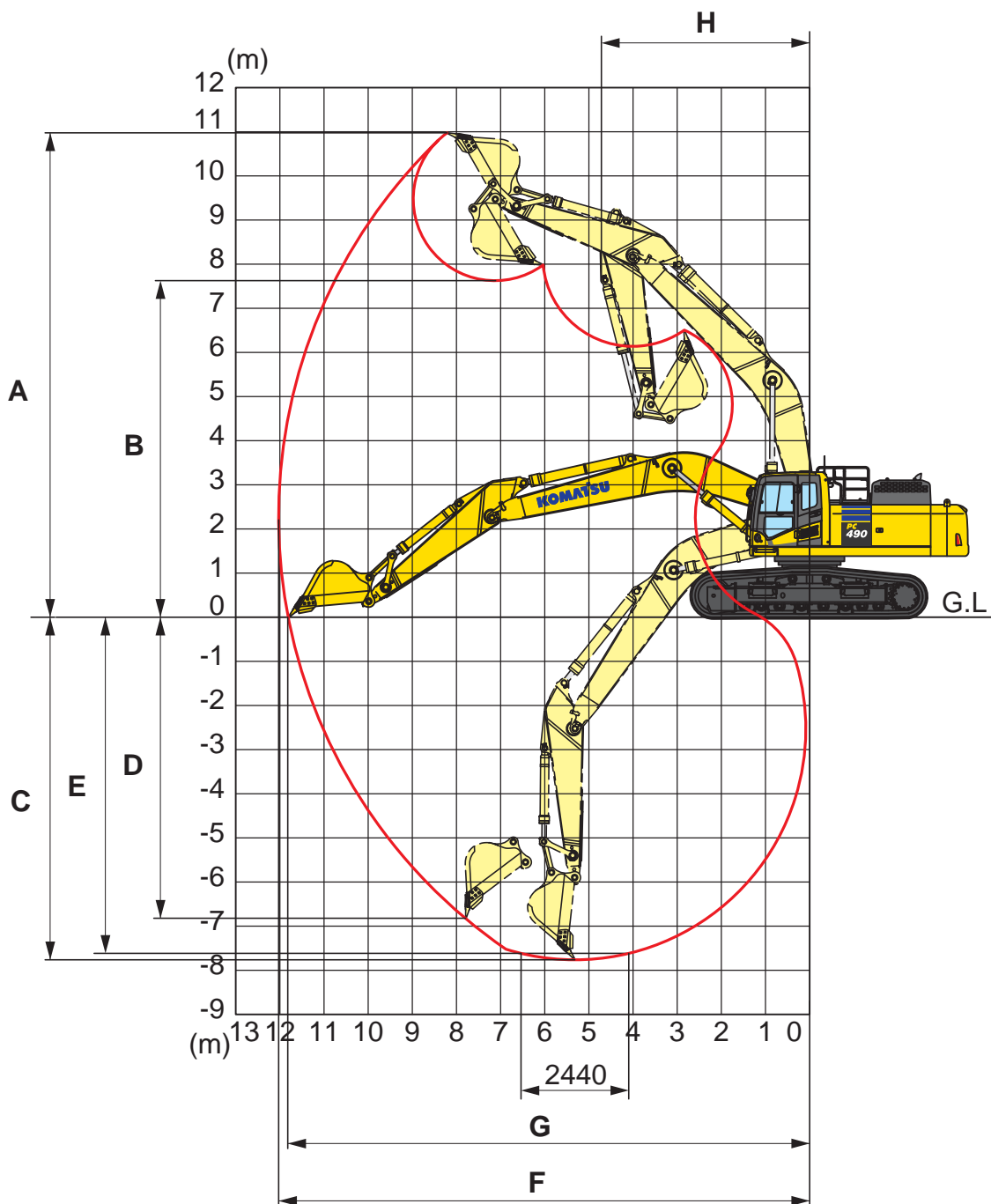







## SHORT BOOM



ARM LENGTH	2,4 m	2,9 m
A Max. digging height	10.510 mm	10.550 mm
B Max. dumping height	7.075 mm	7.115 mm
C Max. digging depth	6.365 mm	6.865 mm
D Max. vertical wall digging depth	4.365 mm	4.950 mm
E Max. digging depth of cut for 2,44 m level	5.630 mm	6.710 mm
F Max. digging reach	10.605 mm	10.985 mm
G Max. digging reach at ground level	10.360 mm	10.750 mm
H Min. swing radius	4.265 mm	4.295 mm

# Lifting Capacity

## PC490-10 MONO BOOM

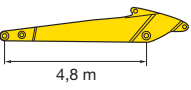
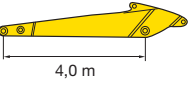
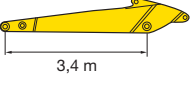
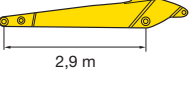
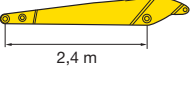
Arm length	A		9,0 m		7,5 m		6,0 m		4,5 m		3,0 m			
	B													
 4,8 m	7,5 m	kg	*6.380	*6.380	*9.480	9.200								
	6,0 m	kg	*6.310	*6.310	*9.820	9.060								
	4,5 m	kg	*6.380	6.200	*10.440	8.830	*11.480	*11.480						
	3,0 m	kg	*6.580	5.950	*11.170	8.550	*12.760	11.090	*15.370	15.260	*20.330	*20.330		
	1,5 m	kg	*6.930	5.860	11.150	8.270	*13.960	10.620	*17.410	14.430	*23.980	21.790		
	0,0 m	kg	*7.460	5.930	10.900	8.030	14.070	10.240	*18.740	13.830	*24.610	20.850	*10.120	*10.120
	-1,5 m	kg	*8.280	6.180	10.730	7.880	13.810	10.000	19.130	13.490	*25.780	20.450	*13.950	*13.950
	-3,0 m	kg	*9.050	6.690	10.670	7.820	13.690	9.890	*18.660	13.360	*24.560	20.390	*18.840	*18.840
	-4,5 m	kg	*9.990	7.630	*10.610	7.900	*13.580	9.930	*17.100	13.430	*22.080	20.570	*25.120	*25.120
	-6,0 m	kg	*9.580	9.480			*10.700	10.180	*14.070	13.690	*17.970	*17.970	*23.550	*23.550
 4,0 m	7,5 m	kg	*7.890	*7.890	*9.970	9.030								
	6,0 m	kg	*7.830	7.520	*10.720	8.940	*11.480	*11.480						
	4,5 m	kg	*7.960	6.950	*11.240	8.740	*12.520	11.400	*14.620	*14.620				
	3,0 m	kg	*8.270	6.640	11.390	8.500	*13.690	10.970	*16.750	14.970	*22.810	22.670		
	1,5 m	kg	*8.770	6.540	11.140	8.270	14.410	10.570	*18.460	14.270	*23.800	21.380		
	0,0 m	kg	8.930	6.650	10.950	8.090	14.090	10.270	*19.320	13.820	*22.690	20.810		
	-1,5 m	kg	9.430	7.000	10.840	7.990	13.910	10.100	*19.230	13.600	*25.360	20.650	*15.150	*15.150
	-3,0 m	kg	*10.420	7.700	10.860	8.010	13.880	10.070	*18.170	13.580	*23.390	20.750	*21.760	*21.760
	-4,5 m	kg	*10.710	9.070			*12.490	10.210	*15.910	13.740	*20.120	*20.120	*25.940	*25.940
	-6,0 m	kg	*9.770	*9.770					*11.580	*11.580	*14.840	*14.840		
 3,4 m	7,5 m	kg	*9.160	*9.160			*11.710	*11.710						
	6,0 m	kg	*9.060	8.180	*11.420	8.860	*12.310	11.650						
	4,5 m	kg	*9.210	7.510	11.590	8.700	*13.280	11.310	*15.730	15.560	*20.530	*20.530		
	3,0 m	kg	9.560	7.170	11.370	8.500	*14.340	10.920	*17.720	14.810	*24.590	22.190		
	1,5 m	kg	9.460	7.070	11.170	8.310	14.410	10.570	*19.130	14.220	*17.760	*17.760		
	0,0 m	kg	9.690	7.220	11.020	8.170	14.150	10.330	19.530	13.880	*20.720	*20.720		
	-1,5 m	kg	10.310	7.660	10.970	8.120	14.030	10.230	*19.100	13.750	*24.620	20.930	*15.450	*15.450
	-3,0 m	kg	*11.410	8.570			*14.020	10.260	*17.580	13.810	*22.140	21.100	*24.050	*24.050
	-4,5 m	kg	*10.880	10.410			*11.020	10.490	*14.650	14.040	*18.250	*18.250	*22.170	*22.170
	-6,0 m	kg												
 2,9 m	7,5 m	kg	*12.150	10.480			*12.310	11.660						
	6,0 m	kg	11.930	8.950			*12.790	11.470	*14.530	*14.530				
	4,5 m	kg	10.840	8.120	11.450	8.570	*13.680	11.130	*16.380	15.280				
	3,0 m	kg	10.310	7.690	11.260	8.390	14.610	10.760	*18.200	14.550				
	1,5 m	kg	10.190	7.580	11.080	8.220	14.270	10.440	*19.330	14.020				
	0,0 m	kg	10.470	7.760	10.960	8.110	14.050	10.240	19.390	13.750				
	-1,5 m	kg	11.270	8.320			13.980	10.180	*18.630	13.690	*23.440	20.890		
	-3,0 m	kg	*12.120	9.500			*13.280	10.270	*16.740	13.800	*20.660	*20.660	*24.100	*24.100
	-4,5 m	kg	*11.370	*11.370					*13.180	*13.180	*16.280	*16.280		
	-6,0 m	kg												
 2,4 m	7,5 m	kg	*13.220	11.430			*13.240	11.620						
	6,0 m	kg	12.840	9.640			*13.540	11.490	*15.500	*15.500				
	4,5 m	kg	11.610	8.710			*14.340	11.190	*17.320	15.260				
	3,0 m	kg	11.020	8.250	11.370	8.510	14.710	10.870	*19.000	14.610				
	1,5 m	kg	10.910	8.150	11.230	8.380	14.420	10.600	*19.820	14.180				
	0,0 m	kg	11.260	8.380			14.260	10.450	*19.590	14.000				
	-1,5 m	kg	12.230	9.060			14.240	10.430	*18.410	14.000	*22.350	21.400		
	-3,0 m	kg	*12.360	10.510			*12.480	10.580	*16.080	14.150	*19.360	*19.360	*20.430	*20.430
	-4,5 m	kg	*10.960	*10.960					*11.520	*11.520	*14.410	*14.410		
	-6,0 m	kg												

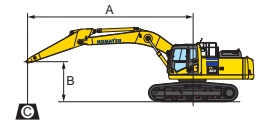

A – Reach from swing center

B – Bucket hook height

C – Lifting capacities

 – Rating over front

 – Rating over side









 – Rating at maximum reach

With 700 mm shoes

Weights:

Bucket linkage and bucket cylinder: 490 kg

## PC490-10 SHORT BOOM

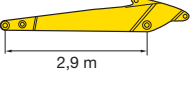
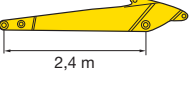
Arm length	A		7,0 m		6,0 m		4,5 m		3,0 m			
	B											
 2,9 m	6,0 m	kg	*12.450	10.000	*12.850	11.700						
	4,5 m	kg	11.950	8.950	*13.650	11.400	*16.100	15.750	*20.300	*20.300		
	3,0 m	kg	11.250	8.450	*14.700	11.050	*18.050	15.050				
	1,5 m	kg	11.100	8.250	14.550	10.700	*19.500	14.450				
	0,0 m	kg	11.400	8.450	14.300	10.450	19.750	14.050				
	-1,5 m	kg	12.350	9.100	14.200	10.350	*19.150	13.950	*24.600	21.250		
 2,4 m	-3,0 m	kg	*13.600	10.600	*13.550	10.400	*17.300	14.050	*21.700	*21.350	*25.850	*25.850
	-4,5 m	kg	*13.100	*13.100			*13.700	*13.700	*17.150	*17.150	*19.850	*19.850
	6,0 m	kg	*12.850	10.100	*13.600	11.700	*15.200	*15.200				
	4,5 m	kg	12.050	9.050	*14.350	11.450	*17.000	15.700	*22.000	*22.000		
	3,0 m	kg	11.400	8.600	14.950	11.100	*18.900	15.050				
	1,5 m	kg	11.300	8.450	14.650	10.800	*20.000	14.550				
	0,0 m	kg	11.650	8.700	14.450	10.650	*19.950	14.250				
	-1,5 m	kg	12.700	9.400	14.400	10.600	*19.000	14.200	*23.650	21.750		
	-3,0 m	kg	*12.850	10.950	*12.650	10.700	*16.650	14.350	*20.400	*20.400	*21.950	*21.950
	-4,5 m	kg	*11.400	*11.400			*11.950	*11.950	*15.200	*15.200		

\* Load is limited by hydraulic capacity rather than tipping. Ratings are based on SAE Standard No. J1097. Rated loads do not exceed 87% of hydraulic lift capacity or 75% of tipping load. Lifting capacity stated is based on lifting with bare arm. When lifting with additional equipment installed to the arm, please subtract the weight of all additional equipment from the values stated.

## PC490LC-10 MONO BOOM

Arm length	A		9,0 m		7,5 m		6,0 m		4,5 m		3,0 m			
	B													
 4,8 m	7,5 m	kg	*6.380	*6.380	*9.480	9.340								
	6,0 m	kg	*6.310	*6.310	*9.820	9.200								
	4,5 m	kg	*6.380	6.310	*10.440	8.970	*11.480	*11.480						
	3,0 m	kg	*6.580	6.060	*11.170	8.690	*12.760	11.270	*15.370	*15.370	*20.330	*20.330		
	1,5 m	kg	*6.930	5.970	*11.870	8.410	*13.960	10.800	*17.410	14.680	*23.980	22.160		
	0,0 m	kg	*7.460	6.040	12.190	8.180	*14.820	10.420	*18.740	14.070	*24.610	21.220	*10.120	*10.120
	-1,5 m	kg	*8.280	6.300	12.020	8.020	*15.160	10.180	*19.160	13.730	*25.780	20.820	*13.950	*13.950
	-3,0 m	kg	*9.570	6.810	11.960	7.960	*14.830	10.070	*18.660	13.600	*24.560	20.760	*18.840	*18.840
	-4,5 m	kg	*9.990	7.770	*10.610	8.050	*13.580	10.120	*17.100	13.670	*22.080	20.940	*25.120	*25.120
	-6,0 m	kg	*9.580	*9.580			*10.700	10.360	*14.070	13.930	*17.970	*17.970	*23.550	*23.550
 4,0 m	7,5 m	kg	*7.890	*7.890	*9.970	9.170								
	6,0 m	kg	*7.830	7.650	*10.720	9.080	*11.480	*11.480						
	4,5 m	kg	*7.960	7.070	*11.240	8.890	*12.520	11.580	*14.620	*14.620				
	3,0 m	kg	*8.270	6.760	*11.860	8.650	*13.690	11.150	*16.750	15.210	*22.810	*22.810		
	1,5 m	kg	*8.800	6.660	*12.410	8.420	*14.690	10.750	*18.460	14.510	*23.800	21.750		
	0,0 m	kg	*9.620	6.770	12.240	8.240	*15.290	10.450	*19.320	14.060	*22.690	21.170		
	-1,5 m	kg	10.520	7.120	12.130	8.140	*15.280	10.280	*19.230	13.840	*25.360	21.020	*15.150	*15.150
	-3,0 m	kg	*10.930	7.840	*11.560	8.160	*14.500	10.260	*18.170	13.830	*23.390	21.110	*21.760	*21.760
	-4,5 m	kg	*10.710	9.230			*12.490	10.390	*15.910	13.980	*20.120	*20.120	*25.940	*25.940
	-6,0 m	kg	*9.770	*9.770					*11.580	*11.580	*14.840	*14.840		
 3,4 m	7,5 m	kg	*9.160	*9.160			*11.710	*11.710						
	6,0 m	kg	*9.060	8.320	*11.420	9.000	*12.310	11.830						
	4,5 m	kg	*9.210	7.640	*11.820	8.850	*13.280	11.490	*15.730	*15.730	*20.530	*20.530		
	3,0 m	kg	*9.590	7.290	*12.340	8.640	*14.340	11.100	*17.720	15.060	*24.590	22.560		
	1,5 m	kg	*10.240	7.200	12.460	8.450	*15.180	10.750	*19.130	14.470	*17.760	*17.760		
	0,0 m	kg	10.790	7.350	12.310	8.310	*15.540	10.520	*19.600	14.120	*20.720	*20.720		
	-1,5 m	kg	11.510	7.800	12.250	8.260	*15.240	10.410	*19.100	14.000	*24.620	21.290	*15.450	*15.450
	-3,0 m	kg	*11.410	8.720			*14.020	10.440	*17.580	14.050	*22.140	21.470	*24.050	*24.050
	-4,5 m	kg	*10.880	10.590			*11.020	10.670	*14.650	14.280	*18.250	*18.250	*22.170	*22.170
	-6,0 m	kg												
 2,9 m	7,5 m	kg	*12.150	10.650			*12.310	11.840						
	6,0 m	kg	*11.930	9.100			*12.790	11.650	*14.530	*14.530				
	4,5 m	kg	*11.890	8.260	*12.130	8.710	*13.680	11.310	*16.380	15.520				
	3,0 m	kg	11.480	7.830	*12.530	8.530	*14.630	10.940	*18.200	14.790				
	1,5 m	kg	11.360	7.710	12.370	8.360	*15.310	10.620	*19.330	14.260				
	0,0 m	kg	11.690	7.900	12.250	8.250	*15.480	10.420	*19.460	13.990				
	-1,5 m	kg	*12.250	8.470			*14.920	10.360	*18.630	13.930	*23.440	21.260		
	-3,0 m	kg	*12.120	9.670			*13.280	10.450	*16.740	14.040	*20.660	*20.660	*24.100	*24.100
	-4,5 m	kg	*11.370	*11.370					*13.180	*13.180	*16.280	*16.280		
	-6,0 m	kg												
 2,4 m	7,5 m	kg	*13.220	11.610			*13.240	11.800						
	6,0 m	kg	*12.870	9.800			*13.540	11.670	*15.500	*15.500				
	4,5 m	kg	*12.750	8.860			*14.340	11.370	*17.320	15.500				
	3,0 m	kg	12.270	8.390	12.660	8.650	*15.190	11.050	*19.000	14.850				
	1,5 m	kg	12.150	8.290	12.520	8.520	*15.720	10.780	*19.820	14.430				
	0,0 m	kg	12.560	8.530			*15.670	10.630	*19.590	14.240				
	-1,5 m	kg	*12.760	9.220			*14.800	10.610	*18.410	14.240	*22.350	21.770		
	-3,0 m	kg	*12.360	10.690			*12.480	10.760	*16.080	14.400	*19.360	*19.360	*20.430	*20.430
	-4,5 m	kg	*10.960	*10.960					*11.520	*11.520	*14.410	*14.410		
	-6,0 m	kg												

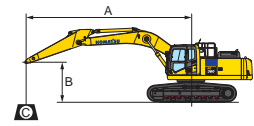

- A – Reach from swing center
- B – Bucket hook height
- C – Lifting capacities

– Rating over front

– Rating over side

– Rating at maximum reach

With 600 mm shoes

Weights:

Bucket linkage and bucket cylinder: 490 kg

## PC490LC-10 SHORT BOOM

Arm length	A		7,0 m		6,0 m		4,5 m		3,0 m			
	B											
 2,9 m	6,0 m	kg	*12.450	10.150	*12.850	11.900						
	4,5 m	kg	*12.450	9.100	*13.650	11.600	*16.100	16.000	*20.300	*20.300		
	3,0 m	kg	12.550	8.550	*14.700	11.200	*18.050	15.250				
	1,5 m	kg	12.350	8.400	*15.450	10.900	*19.500	14.700				
	0,0 m	kg	12.750	8.600	*15.700	10.650	*19.800	14.300				
	-1,5 m	kg	*13.450	9.300	*15.200	10.550	*19.150	14.200	*24.600	21.650		
 2,4 m	-3,0 m	kg	*13.600	10.750	*13.550	10.600	*17.300	14.250	*21.700	*21.700	*25.850	*25.850
	-4,5 m	kg	*13.100	*13.100			*13.700	*13.700	*17.150	*17.150	*19.850	*19.850
	6,0 m	kg	*12.850	10.250	*13.600	11.850	*15.200	*15.200				
	4,5 m	kg	*13.100	9.200	*14.350	11.600	*17.000	15.900	*22.000	*22.000		
	3,0 m	kg	12.700	8.700	*15.300	11.300	*18.900	15.300				
	1,5 m	kg	12.600	8.600	*15.850	11.000	*20.000	14.800				
0,0 m	kg	13.000	8.850	*15.900	10.800	*20.000	14.500					
-1,5 m	kg	*13.200	9.600	*15.100	10.750	*19.000	14.450	*23.650	*22.100			
-3,0 m	kg	*12.850	11.150	*12.650	10.900	*16.650	14.600	*20.400	*20.400	*21.950	*21.950	
-4,5 m	kg	*11.400	*11.400			*11.950	*11.950	*15.200	*15.200			

\* Load is limited by hydraulic capacity rather than tipping. Ratings are based on SAE Standard No. J1097. Rated loads do not exceed 87% of hydraulic lift capacity or 75% of tipping load. Lifting capacity stated is based on lifting with bare arm. When lifting with additional equipment installed to the arm, please subtract the weight of all additional equipment from the values stated.

# Hydraulic Excavator

## PC490/LC-10

### Standard and Optional Equipment

#### ENGINE

Komatsu SAA6D125E-6-A turbocharged common rail direct injection diesel engine	●
EU Stage IIIB/EPA Tier 4 interim compliant	●
Remote hydraulically driven, variable speed, reversible cooling fan	●
Automatic engine warm-up system	●
Engine overheat prevention system	●
Fuel control dial	●
Auto-deceleration function	●
Engine key stop	●
Engine ignition can be password secured on request	●
Alternator 24 V/60 A	●
Starter motor 24 V/11 kW	●
Batteries 2 × 12 V/110 Ah	●

#### HYDRAULIC SYSTEM

Electronic closed-centre load sensing (E-CLSS) hydraulic system (HydrauMind)	●
Pump and engine mutual control (PEMC) system	●
6-working mode selection system; power mode, economy mode, breaker mode, attachment power and attachment economy mode, and lifting mode	●
PowerMax function	●
Adjustable PPC wrist control levers for arm, boom, bucket and swing, with sliding proportional control for attachments and 3 auxiliary buttons	●
Two-mode boom control	●
Prepared for hydraulic quick-coupler	●
Additional hydraulic functions	○

#### UNDERCARRIAGE

Track roller guards	●
Track frame under-guards	●
600, 700, 800, 900 mm triple grouser shoes	○
600 mm double grouser shoes	○
Full length track roller guards	○

#### CABIN

Reinforced safety SpaceCab™; highly pressurised and tightly sealed hyper viscous mounted cab with tinted safety glass windows, large roof window with sun shade, pull-up type front window with locking device, removable lower window, front window wiper with intermittent feature, sun roller blind, cigarette lighter, ashtray, luggage shelf, floor mat	●
Heated, high back air suspension seat with lumbar support, console mounted height adjustable arm rests, and retractable seat belt	●
Automatic climate control system	●
12/24 Volt power supplies	●
Beverage holder and magazine rack	●
Hot and cool box	●
Radio	●
Auxiliary input (MP3 jack)	●
Lower wiper	○
Rain visor (not with OPG)	○

#### SERVICE AND MAINTENANCE

Automatic fuel line de-aeration	●
Double element type air cleaner with dust indicator and auto dust evacuator	●
KOMTRAX™ - Komatsu wireless monitoring system	●
Multi-function video compatible colour monitor with Equipment Management and Monitoring System (EMMS) and efficiency guidance	●
Toolkit	●
Service points	○
Automatic greasing system	○

#### WORK EQUIPMENT

Mono boom (7,1 m)	○
Short boom (6,7 m)	○
2,4 m; 2,9 m; 3,4 m; 4,0 m; 4,8 m arms	○
Komatsu buckets	○
Komatsu breakers	○

#### SAFETY EQUIPMENT

Rear view camera system	●
Electric horn	●
Overload warning device	●
Audible travel alarm	●
Boom safety valves	●
Large handrails, rear-view mirrors	●
Battery main switch	●
ROPS compliant to ISO 12117-2:2008	●
Emergency engine stop switch	●
Arm safety valve	●
OPG Level II front guard (FOPS), hinged type	○
OPG Level II top guard (FOPS)	○
Additional camera, right side mounted	○

#### DRIVES AND BRAKES

Hydrostatic, 3-speed travel system with automatic shift and planetary gear type final drives, and hydraulic travel and parking brakes	●
PPC control levers and pedals for steering and travel	●

#### LIGHTING SYSTEM

Working lights: 2 revolving frame, 1 boom (l.h.)	●
Additional working lights: 4 cab roof (front), 1 cab roof (rear), 1 boom (r.h.), 1 counterweight (rear), beacon	○

#### OTHER EQUIPMENT

Standard counterweight	●
Remote greasing for swing circle and pins	●
Electric refuelling pump with automatic shut-off function	●
Biodegradable oil for hydraulic system	○
Customised paint	○

Further equipment on request

- standard equipment
- optional equipment

Your Komatsu partner:

# KOMATSU

**Komatsu Europe International NV**  
 Mechelsesteenweg 586  
 B-1800 VILVOORDE (BELGIUM)  
 Tel. +32-2-255 24 11  
 Fax +32-2-252 19 81  
[www.komatsu.eu](http://www.komatsu.eu)

UESS14802 06/2012

Materials and specifications are subject to change without notice.  
**KOMATSU** is a trademark of Komatsu Ltd. Japan.