

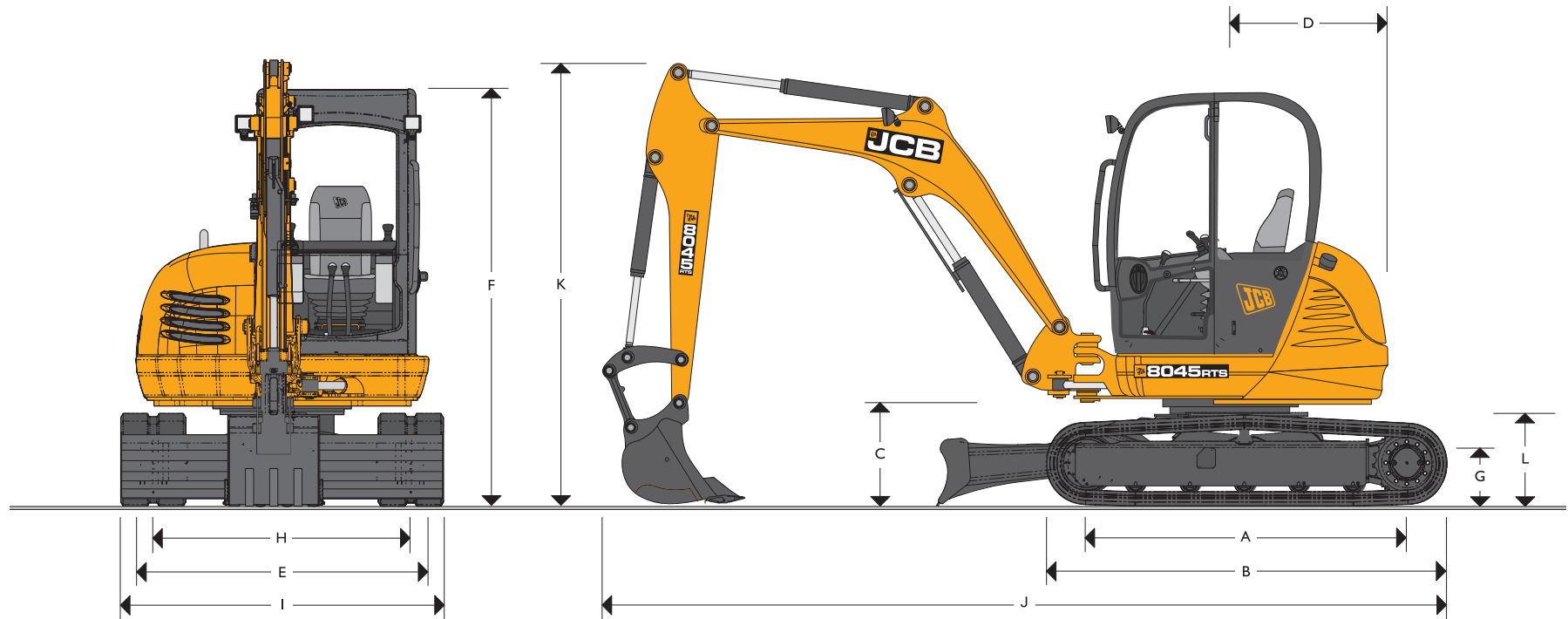

OPERATING WEIGHT: 9,480 lb (4,300 kg) 10,472 lb (4,750 kg) NET ENGINE POWER: 45 hp (33.1 kW) Interim Tier IV



### STATIC DIMENSIONS

Machine Model	8040 ZTS	8045 ZTS
	ft-in (mm)	ft-in (mm)
A Sprocket Idler Centers	6-1 (1845)	6-6 (1990)
B Undercarriage Overall Length	7-10 (2385)	8-4 (2530)
C Kingpost Clearance	2-3 (690)	2-3 (690)
D Tailswing Radius	3-3 (985)	3-3 (985)
E Overall Width of Superstructure	5-11 (1800)	5-11 (1800)
F Height Over Cab	8-5 (2563)	8-5 (2563)

Machine Model	8040 ZTS	8045 ZTS
	ft-in (mm)	ft-in (mm)
G Ground Clearance	1-1 (340)	1-1 (340)
H Track Gauge	5-2 (1580)	5-2 (1580)
I Width Over Tracks	6-6 (1980)	6-6 (1980)
J Transport Length	16-9 (5100)	16-11 (5170)
K Transport Height	8-5 (2563)	9-0 (2736)
L Track Height	1-10 (570)	1-10 (570)



### ENGINE

Machine Model	8040 ZTS & 8045 ZTS	
Model	Perkins 404-22d	
Fuel	Diesel	
Cooling	Water Cooled	
Gross Power SAE J1995	hp (kW) @ 2200 rpm	46.4 (34.1)
Net Power SAE J1349	hp (kW) @ 2200 rpm	45 (33.1)
Gross Torque SAE J1995	lbf ft (Nm) @ 1600 rpm	105.5 (143)
Net Torque SAE J1349	lbf ft (Nm) @ 1600 rpm	101.2 (137.3)
Displacement	cid (cc)	135 (2216)
Gradeability	degrees	35
Starter Motor	hp (kW)	2.72 (2)
Battery	V (A)	12 (75)
Alternator	A	65
Emissions Certification	Interim Tier IV	

### UNDERCARRIAGE

Machine Model		8040 ZTS	8045 ZTS
No of Bottom Rollers (per side)		4	5
Track Width	in (mm)	16 (400)	16 (400)
Ground Bearing Pressure	psi (kg/cm <sup>2</sup> )	4.12 (0.29)	4.27 (0.3)
Ground Clearance	in (mm)	13 (340)	13 (340)
Track Tensioning		Grease	Grease
Travel Speed – Low	mph (kph)	1.7 (2.7)	1.7 (2.7)
Travel Speed – High	mph (kph)	3.4 (5.5)	3.4 (5.5)
Tractive Effort	lbf (kN)	10,858.3 (48.3)	12,319.5 (54.8)

### HYDRAULIC SYSTEM

Machine Model		8040 ZTS	8045 ZTS
Pump		Load Sensing Variable Displacement	Load Sensing Variable Displacement
Nominal Output	lpm	164	164
Nominal Output	gal/min	43.3	43.3
Excavator/Track Main Relief	psi (bar)	3191 (220)	3626 (250)
Slew Main Relief	psi (bar)	3133 (216)	3133 (216)
Auxiliary Hydraulic Flow	gal (l)	18.5(70)	18.5 (70)
Hydraulic Motors		Piston	Piston

### MACHINE WEIGHTS

Machine Model		8040 ZTS	8045 ZTS
Operating Weight*	lb (kg)	9480 (4300)	10,472 (4750)
Transport Weight†	lb (kg)	9315 (4225)	10,307 (4675)
With FOGS Guard	lb (kg)	79 (+36)	79 (+36)
With Steel Tracks	lb (kg)	243 (+110)	309 (+140)

\*Operating weight to ISO 6016 including Cab, rubber tracks, standard dipper, 24 in (600 mm) bucket, full tanks and a 165 lb (75 kg) operator.

†Transport weight is operating weight less a 165 lb (75 kg) operator.

### OPERATOR ENVIRONMENT

		External	Internal
Cab/Canopy Length	ft-in (mm)	4-4 (1328)	3-11 (1187)
Cab/Canopy Width	ft-in (mm)	3-2 (980)	3-1 (933)
Full Internal Height	ft-in (mm)	5-2 (1570)	
Door Aperture Width	ft-in (mm)	1-10 (564)	

### SERVICE CAPACITIES

Machine Model		8040 ZTS	8045 ZTS
Fuel Tank	gal (l)	18 (68)	18 (68)
Engine Coolant	gal (l)	3.6 (13.5)	3.6 (13.5)
Engine Oil	qts (l)	3.8 (3.6)	3.8 (3.6)
Hydraulic System	gal (l)	25.9 (98)	25.9 (98)
Hydraulic Tank	gal (l)	14.5 (55)	14.5 (55)

WORKING RANGE

Machine Model		8040 ZTS	8045 ZTS
Dipper Length	ft-in (mm)	5-0 (1525)	5-8 (1725)
A Max Digging Reach	ft-in (mm)	18-11 ½ (5781)	19-8 (6006)
B Max Digging Reach on Ground	ft-in (mm)	18-5 (5613)	19-2 (5844)
C Max Digging Depth – Dozer Up	ft-in (mm)	10-11 ½ (3341)	11-7 (3542)
Max Digging Depth – Dozer Down	ft-in (mm)	11-7 (3525)	12-3 (3725)
D Max Digging Height	ft-in (mm)	17-2 (5226)	18-0 (5491)
E Max Dump Height	ft-in (mm)	12-7 (3843)	13-1 (3977)
F Max Height to Dipper Nose Pivot Pin	ft-in (mm)	14-8 (4464)	15-1 (4602)
G Max Vertical Wallcut Depth	ft-in (mm)	7-3 (2230)	8-4 (2539)
Min Front Swing Radius (no offset)	ft-in (mm)	8-3 (2514)	8-3 (2514)
Min Front Swing Radius (fully offset)	ft-in (mm)	7-3 (2202)	7-3 (2202)
Boom Swing Left	degrees	60	60
Boom Swing Right	degrees	65	65
Bucket Rotation	degrees	200	200
Dipper Rotation	degrees	125	125
Bucket Tearout	lbf (kN)	8340 (37.1)	9487 (42.2)
Dipper Tearout	lbf (kN)	5171 (23)	5868 (26.1)
Slew Speed	rpm	10	10

STANDARD EQUIPMENT

ROPS & TOPS certified canopy, full audio/visual warning systems, hydraulic slew braking with disc type park brake, control isolator, lockable toolbox, electronic throttle, engine fan guard kit, switchable auto-idle, 12 V power socket, fold-up tracking pedals, lifting points, rubber tracks, servo controls-selectable dual pattern control system (SAE to ISO), suspension seat, boom worklight, single acting auxiliary circuit to dipper, boom ram protection, dozer blades, 5 ft (1,525 mm) dipper – 8040 ZTS, 5 ft 7 in (1,725 mm) dipper – 8045 ZTS.

OPTIONAL EQUIPMENT

ROPS & TOPS certified fully glazed cab (includes heater, interior light, cup holder, door holdback latch within tail swing, gas strut assisted front screen), dual pattern controls (ISO/SAE change-over), front or rear cab/canopy mounted worklights, air conditioning, FOGS roof guard, mirror, toolkit, radio, biodegradable hydraulic oil, fire extinguisher, sunblind (cab builds), battery isolator, Datatag (UK, Italy & Holland only), travel alarm, immobiliser, 1 ton lift option, hose-burst-check-valves, yellow roof moulding, digging buckets, ditching/grading bucket, hydraulic breaker, earthdrill/auger, mechanical quickhitch, longer dozer blade.

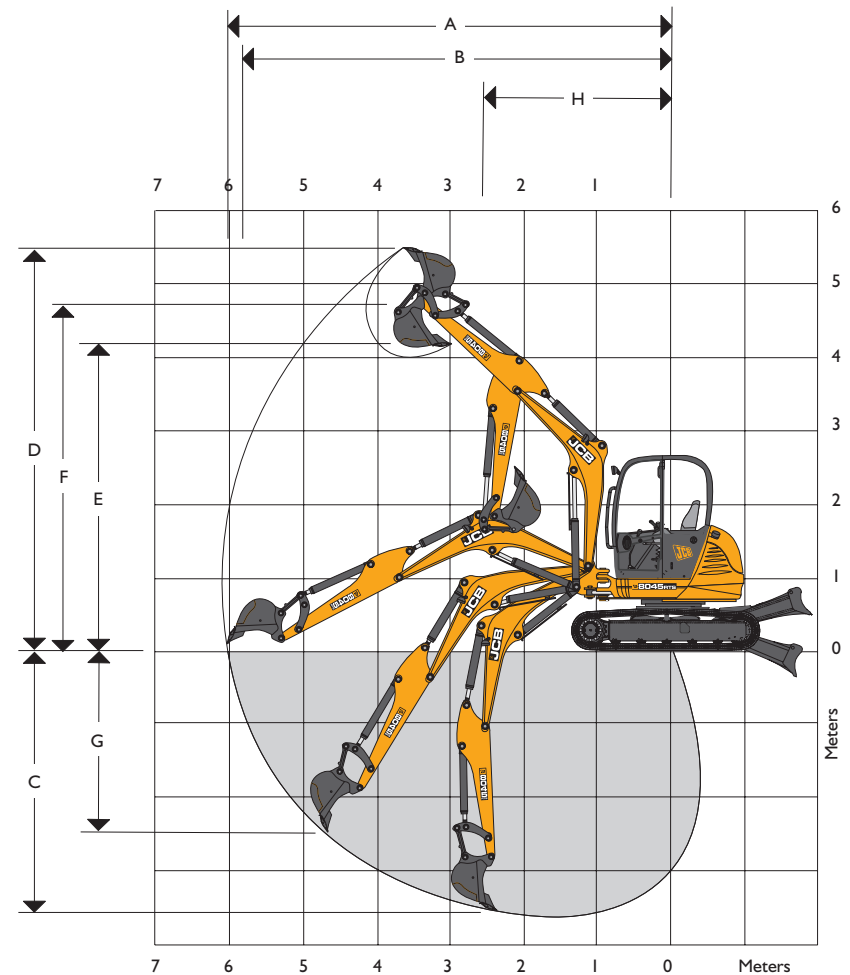



**DOZER BLADE**

Machine Model		8040 ZTS	8045 ZTS
Max Height (above ground)	ft-in (mm)	1-6 (470)	1-6 (470)
Dig Depth (below ground)	ft-in (mm)	1-7 (480)	1-7 (480)
Approach Angle	degrees	27.5	27.5
Width	ft-in (mm)	6-6 (1980)	6-6 (1980)
Height	ft-in (mm)	1-3 (396)	1-3 (396)
Reach in Front of Tracks	ft-in (mm)	2-4 (712)	2-4 (712)

**EEC NOISE LEVELS (95/27/EC DYNAMIC)**

Machine Model		8040 ZTS	8045 ZTS
Cab / Canopy External	LwA (dB)	96	96
Cab Internal	LwA (dB)	80	80

**8040 ZTS LIFT CAPACITIES – Standard Dozer, 16 in (400 mm) Rubber Tracks, 5 ft (1,525mm) Dipper, No Bucket.**

Load Point	Reach from Slew Center																			
	8 ft 2½ in (2500 mm)			9 ft 10 in (3000 mm)			11 ft 6 in (3500 mm)			13 ft 1 in (4000 mm)			14 ft 9 in (4496 mm)			Capacity at Maximum Reach				
Height	Dozer Up	Dozer Down		Dozer Up	Dozer Down		Dozer Up	Dozer Down		Dozer Up	Dozer Down		Dozer Up	Dozer Down		Dozer Up	Dozer Down			
ft-in (mm)	lb	lb	lb	lb	lb	lb	lb	lb	lb	lb	lb	lb	lb	lb	lb	lb	lb	lb	lb	ft-in (mm)
8-2 (2489)							1433	2006*	1609	1389	1962*	1322	1190	1984*	1036	1102	2006*	948	15-5 (4699)	
6-7 (2007)				2424*	2579*	2402*	1499	2314*	1587	1344	2138*	1256	1146	2028*	1036	926	2006*	904	16-1 (4902)	
4-11 (1499)	2380	3967*	2579	2160	3086*	1984	1499	2579*	1543	1234	2292*	1234	1058	2116*	1014	970	2006*	882	16-3 (4953)	
3-3 (991)	2094	4937*	2424	2006	3703*	1895	1389	2865*	1477	1300	2491*	1190	1080	2204*	970	926	2028*	838	16-4 (4978)	
1-8 (508)	2292	5179*	2358	2028	4033*	1851	1499	3152*	1499	1300	2711*	1278	1102	2314*	1080	970	1962*	926	16-4 (4978)	
Ground Level	2138	5422*	2072	1719	4188*	1675	1477	3240*	1344	1300	2865*	1102	1124	2446*	904	1,058	2182*	838	15-8 (4775)	
-1-8 (508)	2028	5003*	2028	1829	4210*	1653	1366	3394*	1322	1168	2799*	1058	992	2358*	904	948	2270*	882	15-0 (4572)	
-3-3 (991)	2072	4981*	2006	1499	4011*	1565	1344	3174*	1256	1168	2491*	1036				904	2160*	948	14-2 (4318)	

**8045 ZTS LIFT CAPACITIES – Standard Dozer, 16 in (400 mm) Rubber Tracks, 5 ft 8 in (1,725 mm) Dipper, No Bucket.**

Load Point	Reach from Slew Center																			
	8 ft 2½ in (2500 mm)			9 ft 10 in (3000 mm)			11 ft 6 in (3500 mm)			13 ft 1 in (4000 mm)			14 ft 9 in (4496 mm)			Capacity at Maximum Reach				
Height	Dozer Up	Dozer Down		Dozer Up	Dozer Down		Dozer Up	Dozer Down		Dozer Up	Dozer Down		Dozer Up	Dozer Down		Dozer Up	Dozer Down			
ft-in (mm)	lb	lb	lb	lb	lb	lb	lb	lb	lb	lb	lb	lb	lb	lb	lb	lb	lb	lb	lb	ft-in (mm)
8-2 (2489)										1851	2270*	1499	1455	2292*	1344	1322	2336*	1102	16-4 (4978)	
6-7 (2007)							2160	2689*	1499	1873	2579*	1433	1499	2380*	1212	1344	2358*	948	16-5 (5004)	
4-11 (1499)	3747	4739*	2931	2446	3615*	2182	2292	3064*	1631	1895	2733*	1389	1411	2535*	1168	1234	2402*	926	16-10 (5131)	
3-3 (991)	3813	5664*	2755	2491	4298*	2050	2226	3460*	1631	1851	2997*	1366	1499	2711*	1124	1190	2424*	904	16-10 (5131)	
1-8 (508)	3769	6127*	2821	2424	4695*	2160	2160	3813*	1719	1653	3196*	1433	1455	2843*	1168	1168	2424*	904	16-10* (5131)	
Ground Level	3350	6193*	2601	2689	5069*	2094	2358	4099*	1697	1940	3460*	1433	1697	3042*	1234	1322	2579*	1080	16-4 (4978)	
-1-8 (508)	3350	6392*	2557	2755	5246*	2050	2182	4518*	1653	1895	3615*	1455	1631	2931*	1234	1433	2579*	1102	15-9 (4801)	
-3-3 (991)	3306	6325*	2667	2314	4871*	2072	1917	4055*	1675	1587	3262*	1389				1234	2557*	1168	14-11 (4547)	

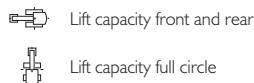

- Notes:**
- Lifting capacities are based on ISO 10567, that is: 75% of minimum tipping load or 87% of hydraulic lift capacity, whichever is the less. Lifting capacities marked\* are based on hydraulic capacity.
  - Lift capacities assume that the machine is on firm, level ground and equipped with an approved lifting point.
  - A bucket must be fitted when lifting, the weight of this bucket must be deducted from the above lift capacities.
  - Lift capacities may be limited by local regulations. Please refer to your dealer.



## A GLOBAL COMMITMENT TO QUALITY

JCB's total commitment to its products and customers has helped it grow from a one-man business into one of the world's largest manufacturers of backhoe loaders, crawler excavators, wheeled excavators, telescopic handlers, wheeled loaders, dump trucks, rough terrain fork lifts, industrial fork lifts, mini/midi excavators, skid steer loaders and tractors.

By making constant and massive investments in the latest production technology, the JCB factories have become some of the most advanced in the world.

By leading the field in innovative research and design, extensive testing and stringent quality control, JCB machines have become renowned all over the world for performance, value and reliability.

And with an extensive dealer sales and service network in over 150 countries, we aim to deliver the best customer support in the industry.

Through setting the standards by which others are judged, JCB has become one of the world's most impressive success stories.



JCB Headquarters Savannah, 2000 Bamford Blvd, Savannah, GA 31322 Tel: (912) 447-2000 Fax: (912) 447-2299 [www.jcb.com](http://www.jcb.com)

JCB reserves the right to change design, materials and/or specifications without notice. Specifications are applicable to units sold in the United States and Canada. The JCB logo is a registered trademark of J C Bamford Excavators Ltd.